



U.S. Department of Energy
Office of Electricity Delivery & Energy Reliability

Electric Distribution



FY06 Annual Program and Peer Review Meeting

San Ramon, California
May 25-26, 2006

Integrated Control of Next Generation Power Systems

Ali Feliachi



advanced power & electricity research center



May 25, 2006

Outline

- Problems & Needs Addressed By The Project
- Technical Challenges of Current Practices
- Overarching Project Goal
- Project Objectives
- Technical Approach
- Life-Cycle Project Budget and Major Milestones
- Current Related Activity
- FY 2006 Expected Performance and Results
- FY 2007 Plan
- Interactions & Collaborations
- Technical and/or Economic Benefits
- Implementation Barriers and Strategies for Mitigation
- Contact Information

Problems & Needs Addressed by the Project

- Problems
 - System performance
 - Availability of power
 - Reconfiguration of distribution systems
 - Power quality
- Needs
 - autonomous agents and distributed resources at the distribution and transmission levels
 - associated business case
 - life cycle development approach (long range)
 - reduction of development costs and risk
 - enhancement of the likelihood of early adoption

Technical Challenges of Current Practices

- Radial distribution systems
- Critical or prioritized loads
- Integration of DERs
- Unplanned and planned islanding
- Protection protocols
- Coordinated control
- Communications limitations
- Administrative and/or legal barriers

Overarching Project Goal

- The successful completion of fundamental and applied R&D leading towards a Multi-Agent System (MAS) Architecture to effectively control next generation power systems.
- Contribute to DOE's vision for an intelligent interoperable grid of the future

Project Objectives

- Advance the multi-agent systems technical performance to enable intelligent control of current flows in modern electricity delivery systems.
- Assess the economic value of increasing intelligence within an actual electric utility T&D system, including integration of various distributed resources and load management technologies.

Technical Approach

- Utilize distributed intelligence to form robust networks, and allow reconfiguration based on situational awareness.
- Develop distributed agents for energy management to reach a globally acceptable solution with limited amount of communication.
- Examine philosophy of implementing decentralized control algorithms
- Apply envisioned improvements and advantages of a multi-agent based control framework to build the energy management system for substations. 7

Life-Cycle Project Budget and Major Milestones

- Project Budget — FY 06: \$ 1,000,000
 - NETL: \$250,000
 - WVU: \$750,000
- Major Milestones towards Success
 - **MAS for Energy Management**
 - Distribution circuits/microgrid
 - **MAS for Effective Control**
 - steady-state and transient regimes
 - **MAS for T&D Systems**
 - mitigation of contingency impacts
 - **Economic Assessment of MAS**

Current Related Activity - MAS

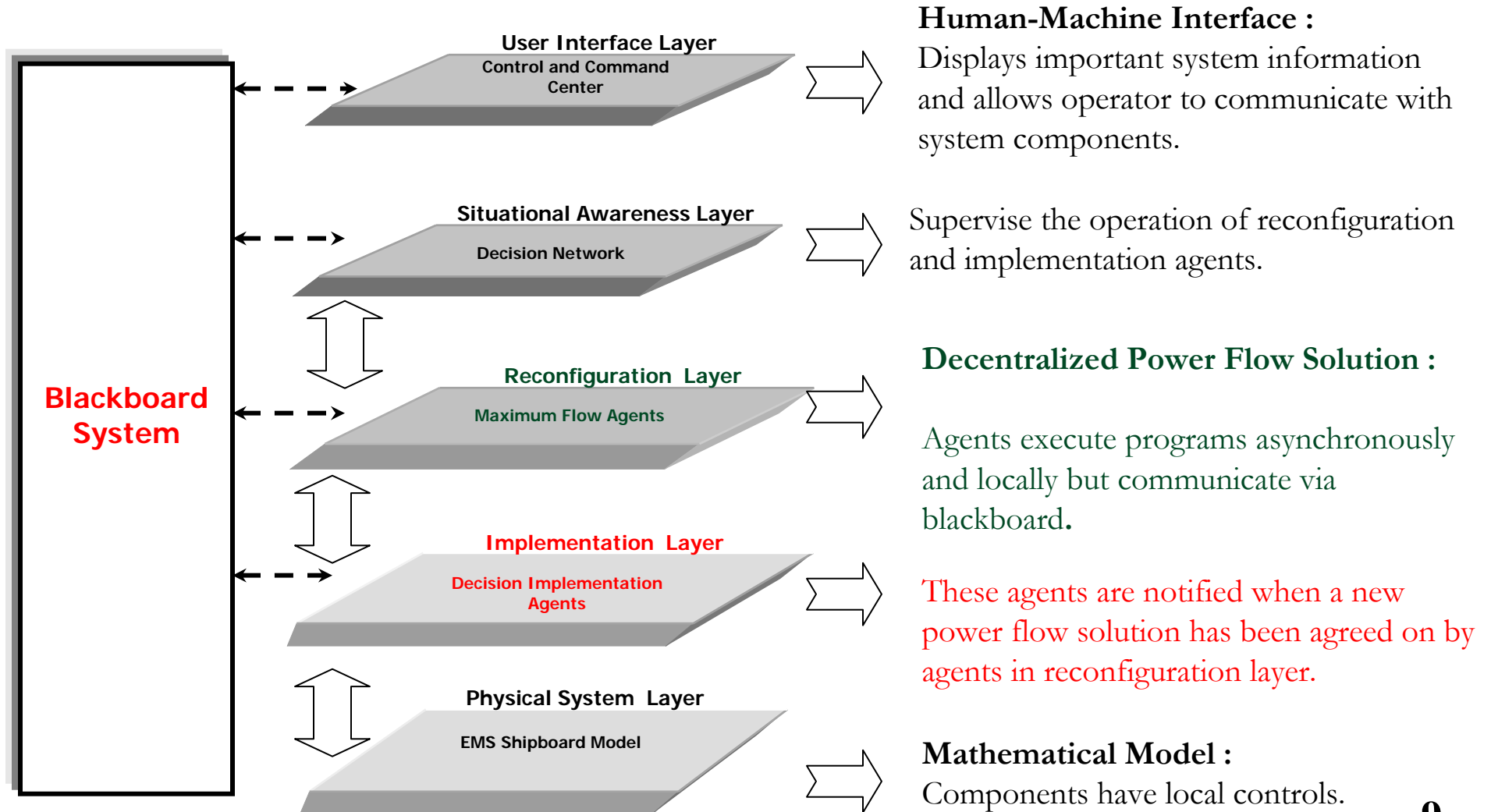

Shipboard Power System

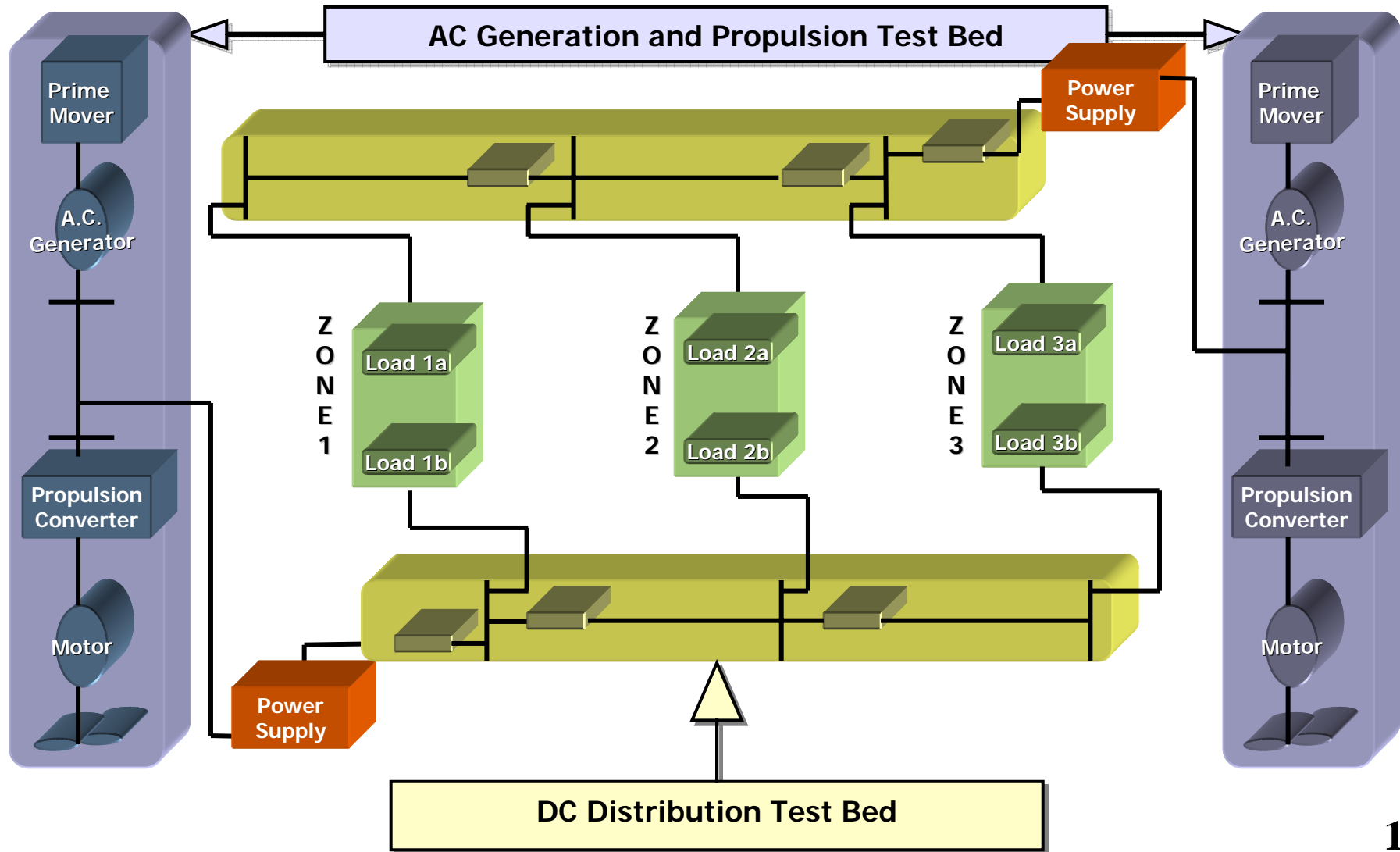

Agent's maximum flow algorithm

Current inflows from neighbors (flow: value, capacity, priority)

Current outflows to neighbors

Distance value of neighbors

Number of agents

Updated inflows from neighbors

Updated outflows to neighbors

Status

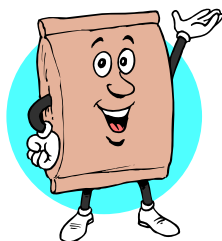

Local information/goals:

1. Demand
2. Priority

1. Could Inflow be increased?
→ Update believed distance value
2. Inflow > Outflow?
→ Reduce lowest priority outflow.
3. Inflow < Outflow AND Outflow can be increased?
→ Increase inflow allow highest priority path.
4. Inflow < Outflow AND Outflow cannot be increased?
→ Push back demand.
5. Flows violate capacity?
→ Reduce flows accordingly.
6. Priority of demands changed?
→ Update supplied/unsupplied demand prio.
7. Status changed?
→ Publish status to blackboard.

11

EMS Case Study

Command and Control Center

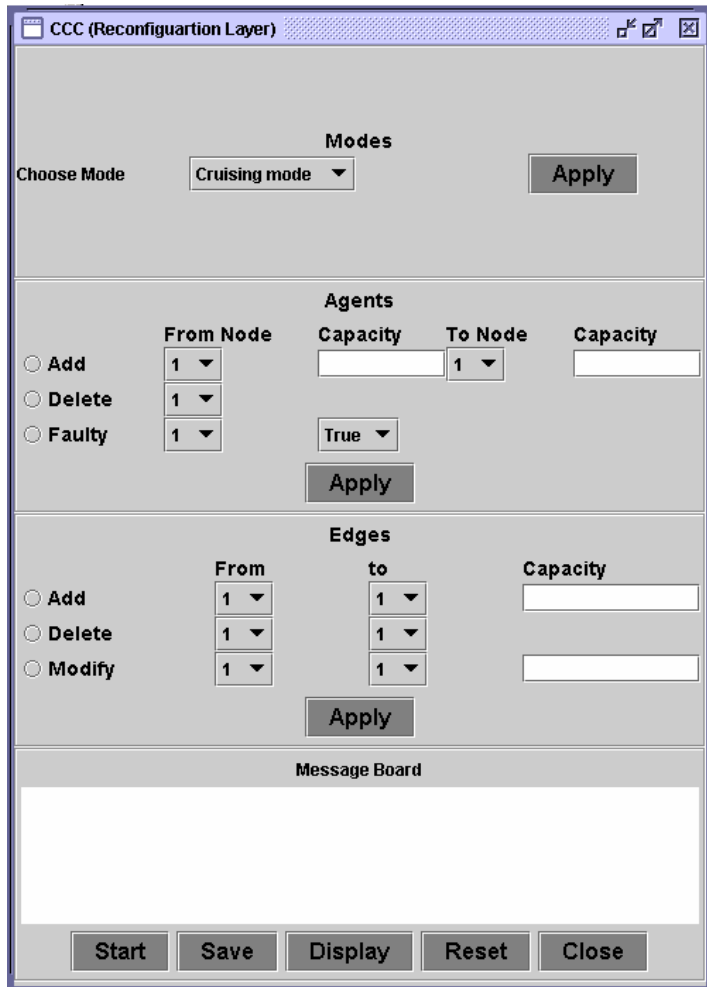

Decision implementation agents

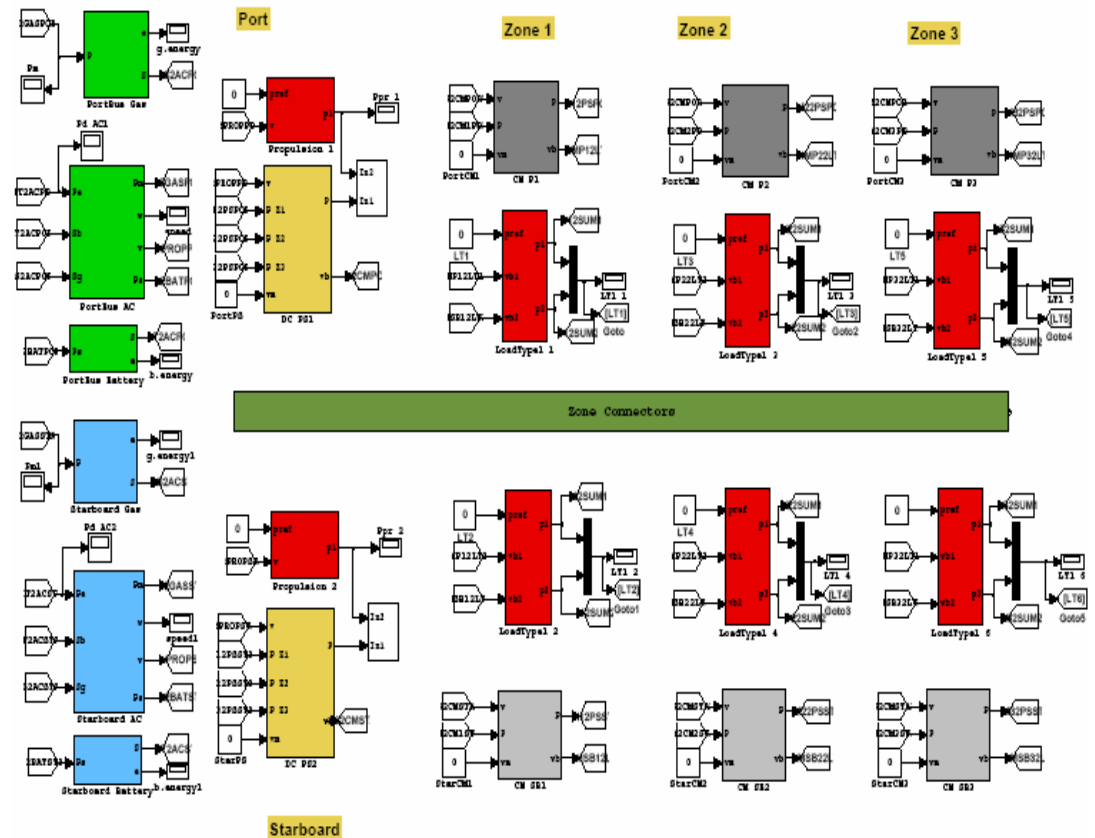

EMS Case Study

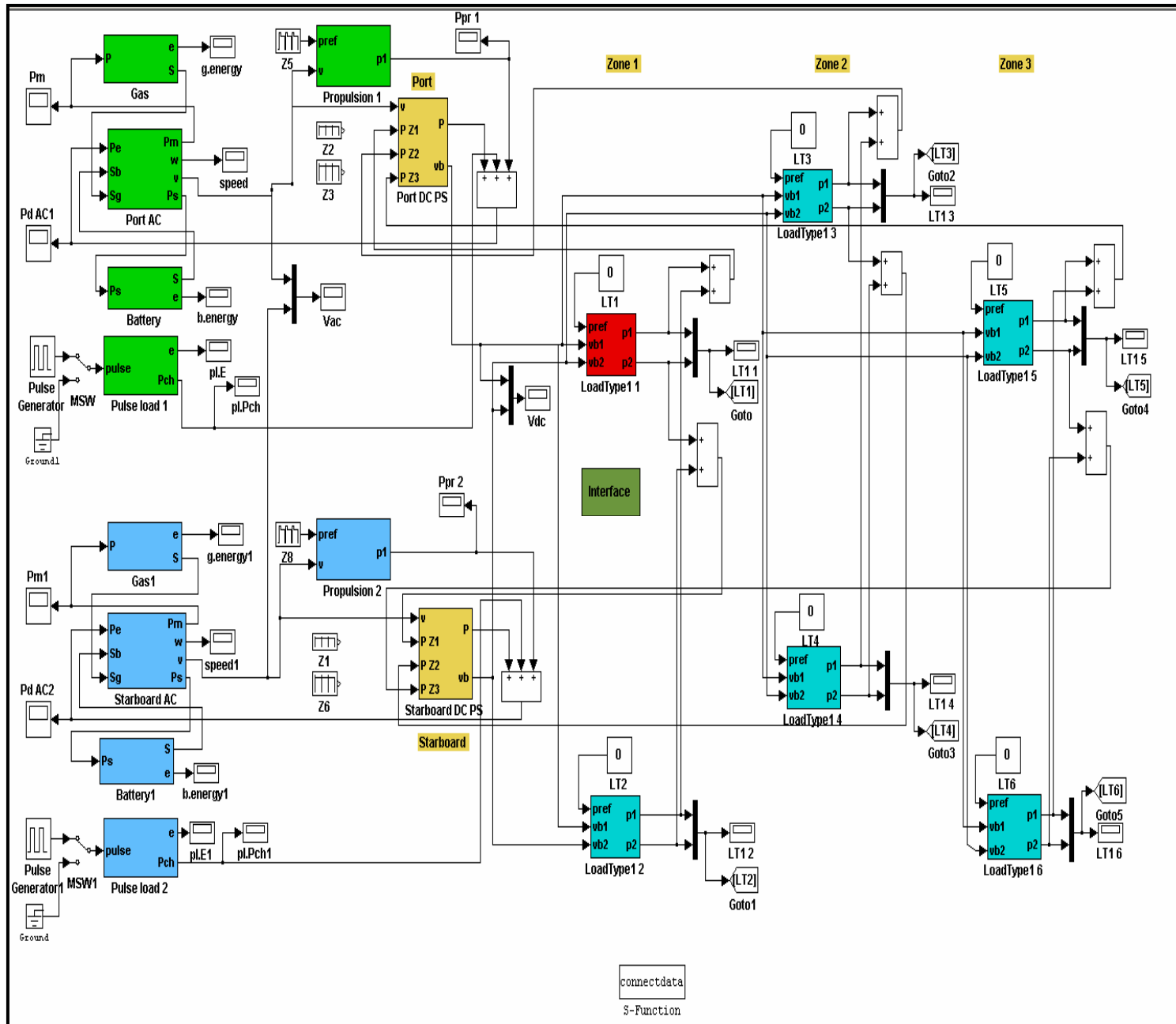

FY 2006 Expected Performance and Results

- Performance
 - Anticipated start date for project is July 1, 2006
- Expected Results
 - Assessment of the multi-agent systems developed during this project and their interaction with electricity delivery control strategies and operating schemes/devices, and DG interconnection “packages”.
 - Demonstration, through simulation and prototyping, of the capabilities, effectiveness and accuracy of the multi-agent systems developed during the course of this project.

Multi-agents for the SCE's COF test system

- SCE's COF for **"Real-World"** test & evaluation and lessons learned feedback
- Demonstration, thru simulation, of the capabilities, monitor effectiveness and accuracy of the MAS

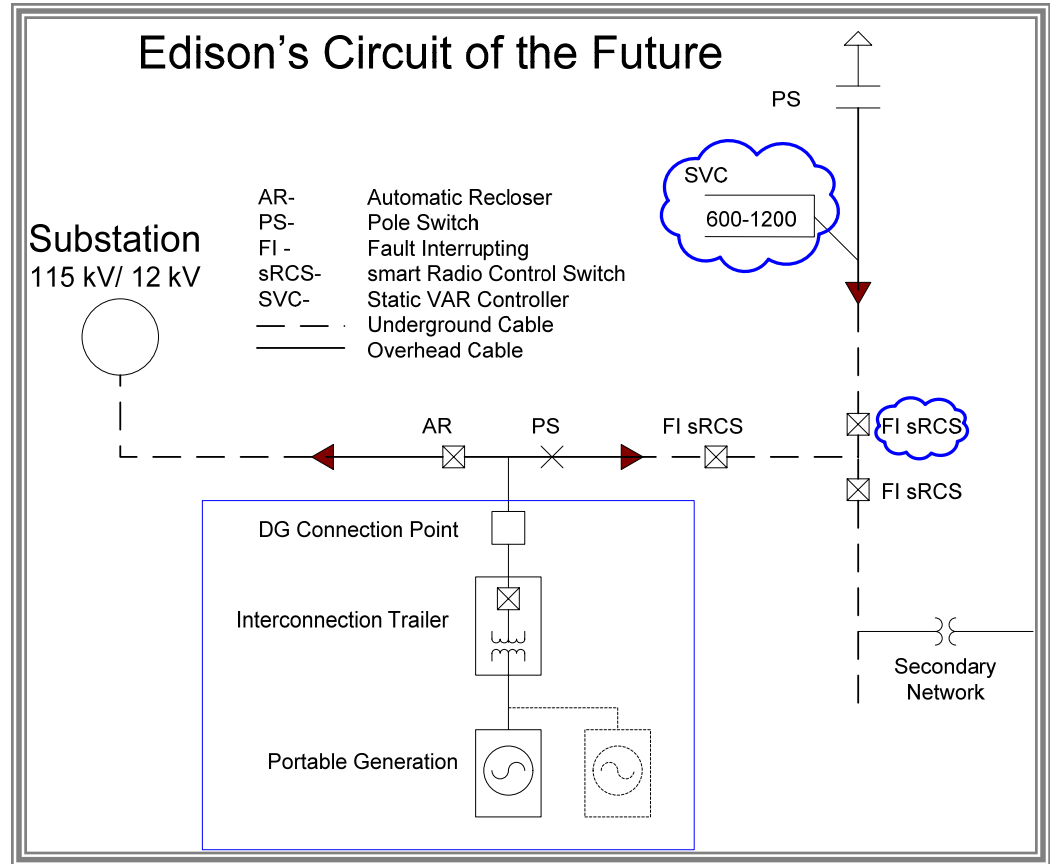

Ref: "Distributed Generation's Role in the Distribution Circuit of the Future" By Russ Neal
Manager of Distribution Engineering, Southern California Edison, SECA Workshop, April 2005 **15**

FY 07 and FY 08 Plans

- Goals for Requested Funding in FY07 and FY08
 - MAS for Effective Control
 - steady-state and transient regimes
 - MAS for T&D Systems
 - Economic Assessment of MAS
- Expected Outcomes
 - Development of agents to be commercially viable with the ability to incorporate control intelligence into DR technologies.
 - Integration of these technologies and analysis of their benefits and cost-effectiveness on larger scale intelligent interoperable grid.

Interactions & Collaborations

- DOE
 - Office of Electricity Delivery and Energy Reliability (OE)
 - NETL Office of Science & Engineering Research (OSER)
- Southern California Edison - Distribution & Advanced Engineering
 - Policy/Technical Advisory Support
- California Energy Commission
 - Potential Participant and Source of Support
- West Virginia University
 - Providing Cost Share Support

Technical and/or Economic Benefits

- Technical Benefits
 - Provide answer to problem of stressed substations
 - Help system operators in coping with
 - routine operations
 - maintenance
 - emergencies
 - optimize life-time and cost performance
 - Improve reliability and power quality at the distribution level
- Economic Benefits
 - Implement Life Cycle Directed R&D
 - reduced risk exposure
 - enhanced capital recovery
 - Reduce power outage impacts
 - reduce likelihood
 - limit physical & temporal exposure

Implementation Barriers and Strategies for Mitigation

- Implementation Barriers:
 - Cost (upgrade circuits, DERs)
 - Compatibility with legacy systems
- Strategy for Mitigation
 - Demonstrate Benefit and value-added

Contact Information

Ali Feliachi

Advanced Power & Electricity Research Center
P.O. Box 6109
West Virginia University
Morgantown, WV 26506-6109

Phone: 304-293-0405 ext. 2529

Fax: 304-293-8602

e-mail: alfeliachi@mail.wvu.edu

website: <http://www.aperc.wvu.edu>

20