

Detroit Edison  
Advanced Communication &  
Control of Distributed Energy  
Resources

Electric Distribution R&D Annual Peer Review  
Meeting May, 2006

**Principal Investigator**  
**Hawk Asgeirsson**  
**Supervising Engineer**  
**Distributed Resources Planning**  
**DTE Energy – Detroit Edison**  
**asgeirssonh@DTEenergy.com**  
**313-235-9371**

**Richard Seguin**  
**Principal Engineer**  
**Distributed Resources**  
**SeguinR@DTEenergy.com**  
**313-235-9598**

**DE-FC02-04CH11234**

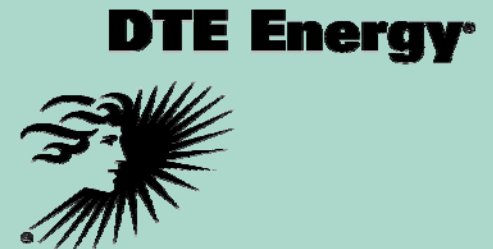

## Present Problem



- Distributed Energy Resources (DER) located on the electric distribution system are not effectively utilized
- Electric utilities do not have a way to use DERs as a resource option to support the electric distribution system
  - Parallel operation
  - Standby operation
- DER asset owners do not have the means to participate in the energy market
- Generator and T&D utility communication relies on private networks



## Technical Challenges

- Aggregate multiple small DERs within an ISO
  - Register DERs in the market
  - Aggregate by LMP node
  - Market the DERs
- Move from a dedicated central system operation center (SOC) to a distributed SOC
- Need a secure and inexpensive communication system
- Manage potential loss of communication
- Trading facilitation with the energy market
- Modeling tools to manage the electric distribution system



# Technical Challenges

- **Metering:**
  - Point of Common Coupling meters are not available for all DER sites
  - Temporary-meters (~\$3000) installed vs. permanent SCADA (~\$30,000)
  - Temporary-meter data path through DR-SOC
- **Security:**
  - Data encryption of all data paths is critical – combination of VPNs and SSL
  - Password protection of all control interfaces – limit user access
  - Physical security of all servers and interface terminals – ID card access, etc
- **Sellback vs. Non-Sellback:**
  - Energy offer dependant on site's ability to export power to the grid
  - Load-forecasting at the point of common coupling critical for non-sellback
  - Interconnection requirements for sellback sites require a minimum utility-to-DR ratio be maintained
- **Integration of Communications:**
  - Passing data between control centers
  - Energy Aggregator requires a flexible architecture for communicating with multiple parties, running different systems, using multiple protocols
  - Integration with ISOs for participation in energy market

## Project Objective



- To develop and demonstrate communication and control solutions to enable large numbers of distributed energy resources (DER), from varying suppliers, to be operated and integrated together to achieve optimization in power quality, power reliability, and economic performance.
- Allow the owners of various DERs to have their resources operated in a safe manner that protects the electric utility distribution network and personnel that may be working on the network.

# Technical Approach Phase II

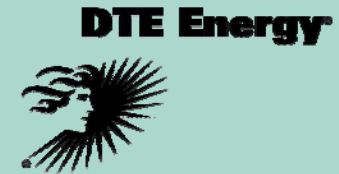

- **Secure Socket Layer Integrated with ICCP (ICCP TASE.2)**
- **Additional DER Units to be added**
- **Aggregate unit to system nodes**
- **Register DERs in the MISO market – Demand Response Resource**
- **Develop Market Procedures with MISO**
- **Comprehensive Economic Dispatch**
- **Develop Forecast Load Program based on weather dependent Load Research Statistics**
- **Forecast Real Time and day ahead loading by utilizing temperature sensitive load research statistics**
- **Build Inter-control room templates that can be used for monitoring and multiple party control**
- **Bid into the day a head market**
- **Complete MISO settlement of aggregated DER units**
- **Leave a working Demand Response mechanism with in the Utility SOC for use in the 2006 Summer**

# Technical Approach Phase II



- **Modify DEW's Reconfiguration for Restoration Program to make use of DERs in power restoration operations**
- **Create a new DEW Contingency Analysis Program that may be used to evaluate DER Spinning Reserve needed for a distribution system containing Aggregated DERs**
- **Modify DEW's DG Control Application to interface to Economic Dispatch of Aggregated Units**
- **Evaluation of System Reliability improvements with DERs being used with Reconfiguration for Restoration**

# Technical Approach Phase II



## **The Utility Model**

- **All DER first goes through the wires for evaluation**
  - **Determine wires operating constraints**
  - **Potential need and or additional benefit**
  - **Quantify distribution wires capacity and reliability**
  - **Avoiding transfer trip by communicating circuit loading to DER controls**
  - **Modify DEW's DG Control Application to interface to Economic Dispatch of Aggregated Units**
  - **System Reliability improvements with DERs being used with Contingency Analysis & Reconfiguration for Restoration**

# Communication Architecture



## Business Model

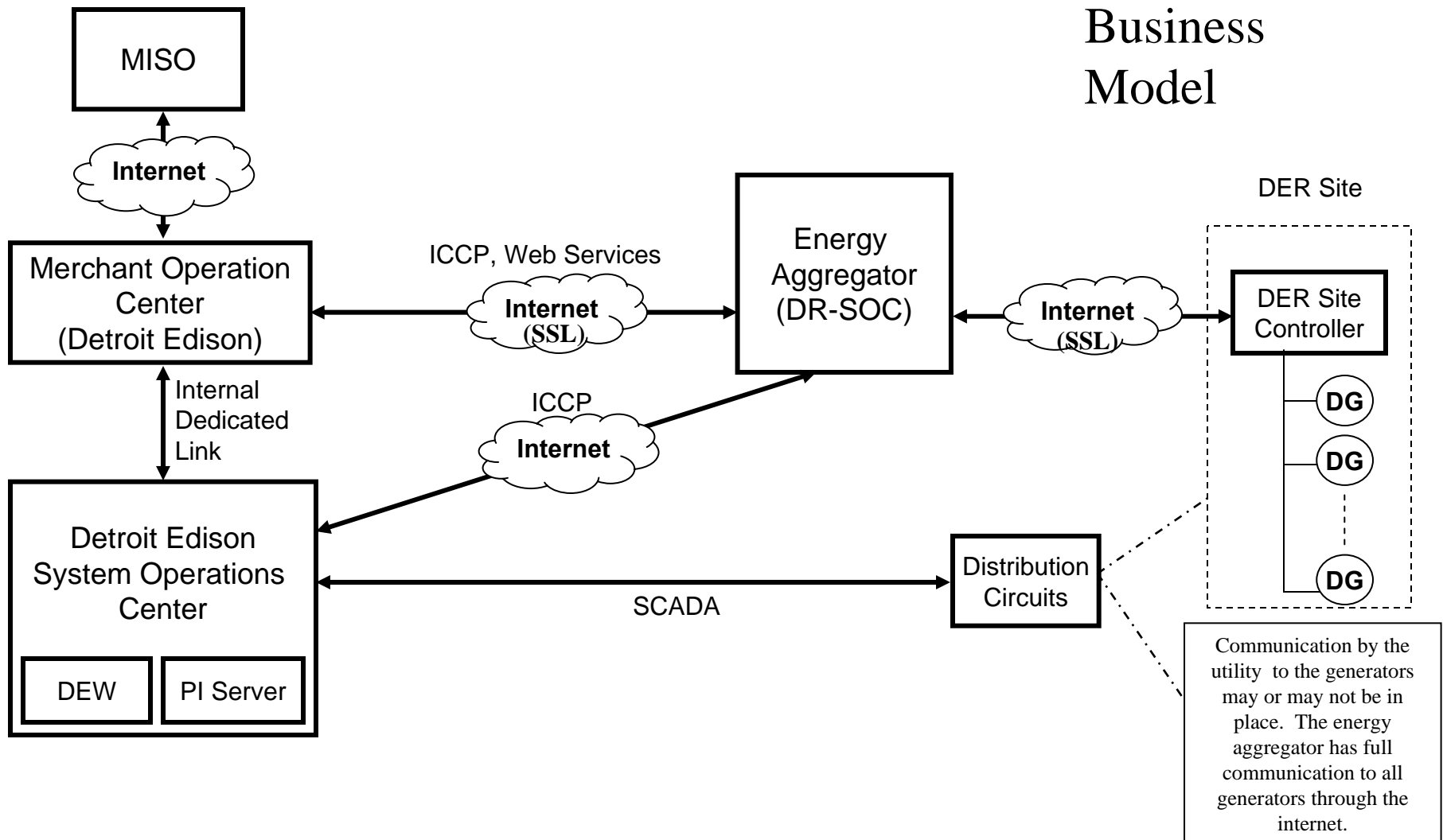



# DR-SOC / Energy-Aggregator

- **DER Site Aggregation**

- **DER Sites in the Detroit Edison service area are grouped into Aggregate Zones based on the transmission node to which they are assigned**
- **Aggregate Zones are registered as CP (Commercial Pricing) nodes with MISO for inclusion in the energy market**
- **Energy offers for MISO are generated on an aggregate zone level**

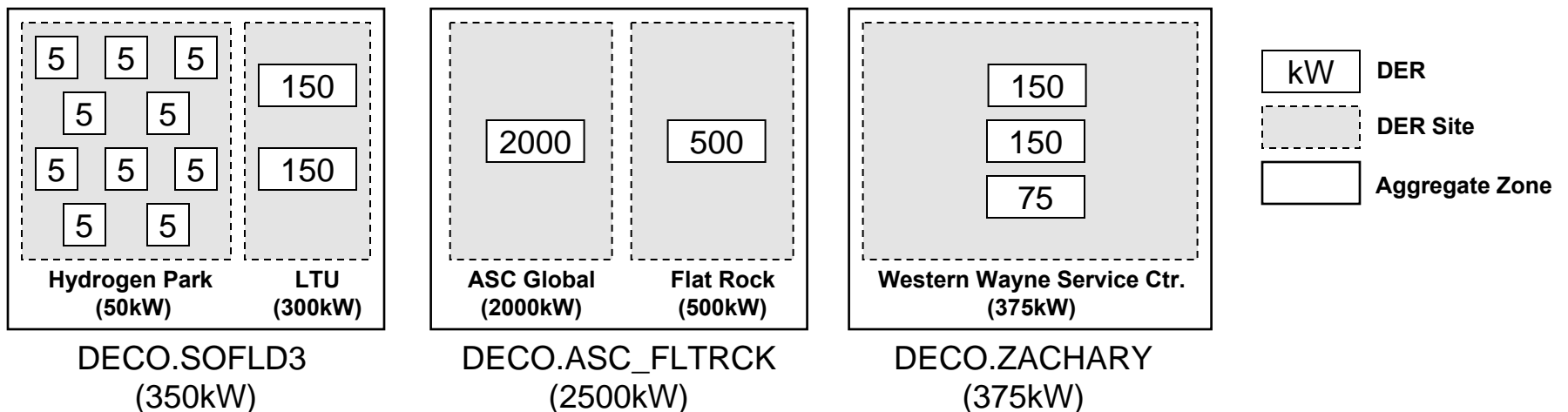

# DR-SOC / Energy-Aggregator



- **Economic Dispatch Algorithm**
  - Calculate hourly day-ahead (24 hours) forecast
  - Algorithm considers DEW recommendations in its calculations including must-runs and load-forecasts
  - Day-ahead commands held until scheduled execution time and issued to DER site based on MISO acceptance and real-time market conditions
  - Sellback vs. Non-sellback consideration



- **Integration with the Midwest ISO Energy Market**
  - **Project DER registered with MISO separately from Detroit Edison generation to ease financial settlement process**
  - **Nearly all communication between Energy-Aggregator (DR-SOC) and MISO occurs through the MOC using nMarket Web Services and ICCP**
  - **Communication with MISO includes:**
    - **Energy Offer** (DR-SOC to MOC, Web Service, daily)
    - **Offer Acceptance** (MOC to DR-SOC, Web Service, daily)
    - **Settlement Meter Data** (DR-SOC to MOC, Web Service, daily)
    - **Real-Time Notifications** (MISO to DR-SOC, Web Service, real-time)
    - **Real-Time Meter Data** (DR-SOC to MOC, ICCP, real-time)



# Detroit Edison MOC / Midwest ISO

- **Offering DER into the MISO Market**
  - Price curve submitted for each aggregate zone for each hour of the day-ahead
  - MISO clears the market by 17:00, indicating which curve, if any, it has accepted
  - The offers cleared in the day-ahead market begin executing at midnight

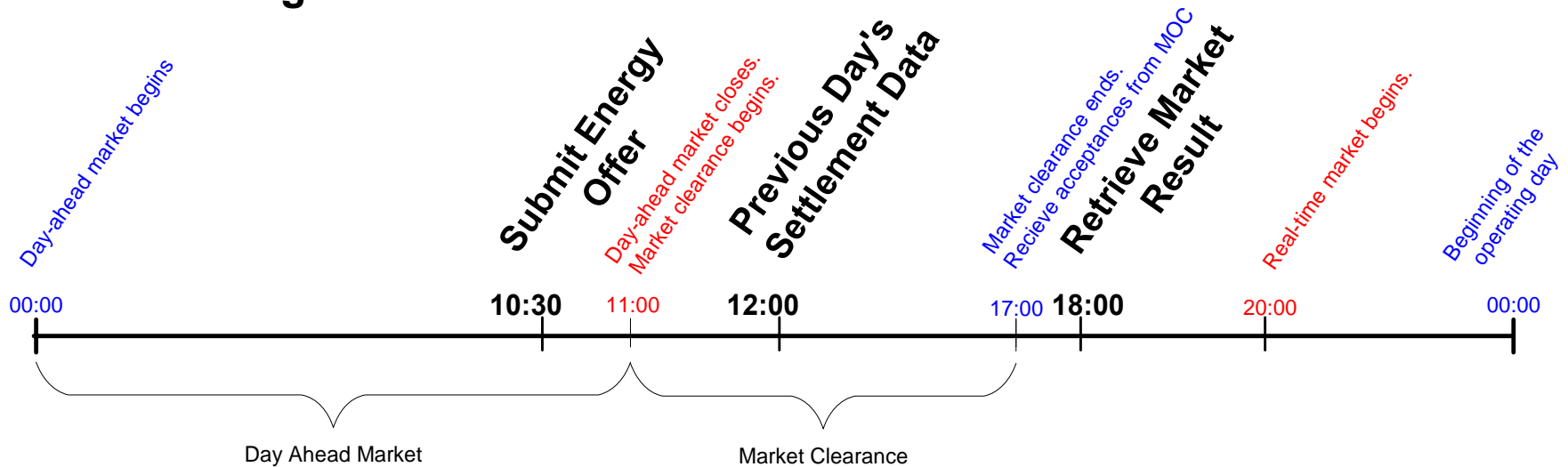

# Detroit Edison SOC



- **System Operations Center**
  - Receive DER site and circuit data from SCADA and DR-SOC (over ICCP)
  - Distributed Energy Workstation
  - PI-Process Book operator interface for monitoring and controlling DER

# DEW Modeling



## Constraints

DG needed for Demand Management  
Customer Hours DG not available  
Total run hours not to exceed e.g. diesel air permit limits  
Circuit Level Restrictions

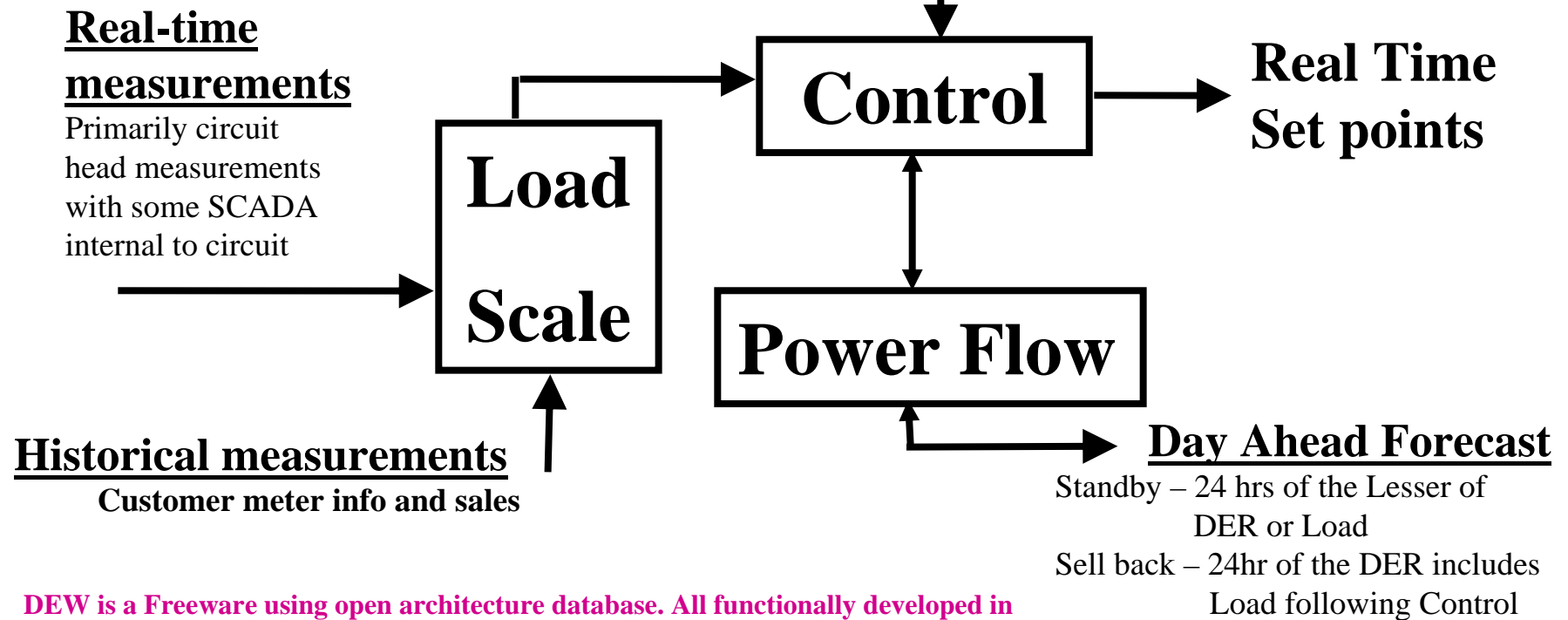

DEW is a Freeware using open architecture database. All functionally developed in this project will be included in DEW.

# PI Process Book General Display

## Real Time

## Day Ahead

5/16/2006 11:23:16 AM

### COMMUNICATION LINK

Peaker Morning Report  
 Contacts and SOP  
**Total DER KW = -0.09 KW**

DTE SOC  
 DTECH

| Total Generation | Circuit Avg. Load | DG Status Legend  | DEW Suggested Action | Participating Legend  |
|------------------|-------------------|---|----------------------|---|
| KW               | Amps              | <div style="display: inline-block; width: 15px; height: 15px; background-color: red; border: 1px solid black;"></div> - OFF<br><div style="display: inline-block; width: 15px; height: 15px; background-color: green; border: 1px solid black;"></div> - ON<br><div style="display: inline-block; width: 15px; height: 15px; background-color: cyan; border: 1px solid black;"></div> - BAD STATE | KW      KVAR         | <div style="display: inline-block; width: 15px; height: 15px; background-color: red; border: 1px solid black;"></div> - NOT PARTICIPATING<br><div style="display: inline-block; width: 15px; height: 15px; background-color: yellow; border: 1px solid black;"></div> - PARTICIPATING<br><div style="display: inline-block; width: 15px; height: 15px; background-color: cyan; border: 1px solid black;"></div> - BAD STATE |

### Site #      CIRCUIT NAME - GENERATOR

|   |   |
|---|---|
| 1 | ANGOLA DC8862 - Lawrence Tech. U. 150+150KW NG  |
| 2 | BROOKS DC8081 - Meadowbrook Insurance 800KW D.  |
| 3 | CRESTWOOD DC8307 - S.Y.Systems 500KW Diesel     |
| 4 | DUVALL DC9455 - Karmann Manufacturing 1000KW D. |

| Total Generation | Circuit Avg. Load | DG Status | DEW Suggested Action | Participating In Market |
|------------------|-------------------|-----------|----------------------|-------------------------|
| 300 KW           | 263 Amps          | ●● 0 KW   | 0 KW    0 KVAR       | ● 0 KW                  |
| 800 KW           | 204 Amps          | ● 0 KW    | 0 KW    0 KVAR       | ● 0 KW                  |
| 500 KW           | 252 Amps          | ● 0 KW    | 0 KW    0 KVAR       | ● 0 KW                  |
| 1000 KW          | 119 Amps          | ● 0 KW    | 0 KW    0 KVAR       | ● 0 KW                  |

|    |  |
|----|--|
| 5  | EMERICK DC2925 - Washtenaw County Bldg4 255KW    |
| 6  | FARMINGTON DC8892 - Batsford 150KW Nat Gas       |
| 7  | FISHER DC8188 - ASC Global 2000KW Diesel         |
| 8  | FISHER DC8188 - Flat Rock Comm.Center. 500KW     |
| 9  | FRISBIE DC2125 - Metropolitan Baking 600KW D     |
| 10 | <b>GOLF DC8518 - 2MW Diesel Generator</b>        |
| 11 | GROSSE ILE DC 2841 - Grosse Ile Schools 1MW      |
| 12 | <b>WANHOE DC1760 - 1.5.MW Bi-fuel Generator</b>  |
| 13 | JOSLYN DC9182 - Alps Automotive 500KW Dies       |
| 14 | MEDINA DC8533 - Adell Comm. 600KW Diesel         |
| 15 | MILFORD DC8103 - Milford Junction-MCN 1MW N      |
| 16 | PIONEER DC8793 - Warde Labs 600KW Diesel         |
| 17 | SHELDON DC9508 - Arctic Colc Storage 750KW       |
| 18 | SHORES DC1770 - Greek Orthodox Church 1MW        |
| 19 | SOUTHFIELD DC9010 - Southfield 26KW Solar + 50K  |
| 20 | SPRUCE DC9874 - Washtenaw County Bldg3 200KW     |
| 21 | SUNSET DC9016 - Farmington 85KW Nat Gas          |
| 22 | TIENKEN DC8850 - Beaumont Dialysis 150+150 N     |
| 23 | <b>UNION LAKE DC1688 - Union Lake 2MW Diesel</b> |
| 24 | Webster DC371 - 500 KW Diesel                    |

|            | UNIT 1 | UNIT 2 |            |
|------------|--------|--------|------------|
|            | ACT.   | ACT.   | REC.       |
| X AMPS     | 0      | 0      |            |
| Y AMPS     | 0      | 0      |            |
| Z AMPS     | 0      | 0      |            |
| TOTAL KW   | 0      | 0      | Pt Created |
| TOTAL KVAR | 0      | 0      | Pt Created |
| TOTAL KVA  | 0      | 0      |            |
| TOTAL PF   | 1.00   | 1.00   |            |
| X-Y Volts  | 0      | 0      |            |
| Y-Z Volts  | 0      | 0      |            |
| Z-X Volts  | 0      | 0      |            |

### Beaumont Dialysis

Tienken DC 8850

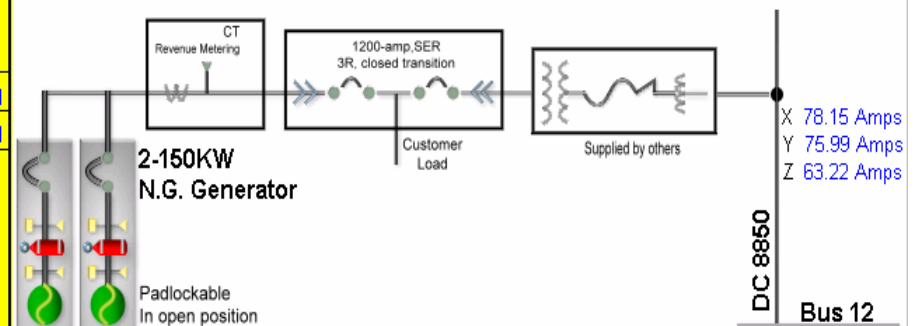

**Tienken**  
 X-Y 125.40 V  
 Y-Z 125.40 V  
 Z-X 124.40 V

Contacts and SOP  
 Enable Control  
 Check if Procedure has been followed  
 Communication Link  
 DTE SOC  
 DTECH

Override Setting 150    Current Status    Current Status    Override Setting 150

OFF    ON    Status    OFF    ON

Circuit phase currents  
 Circuit phase voltages

**Total Generation    18,216 KW**



# DER Point of Common Coupling

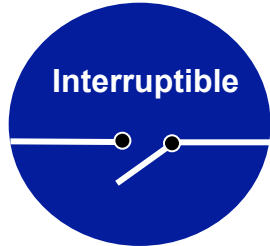

## **Interruptible Load**

**1 MW Load**

**Benefit 1 MW**

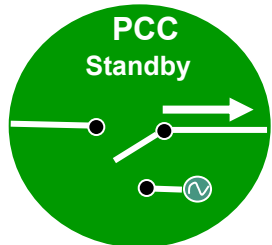

## **Standby Generator non-parallel non-sellback mode**

**1 MW Load      2 MW DG**

**Benefit 1 MW**

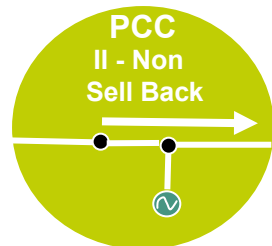

## **Distributed Generation parallel non-sellback mode**

**1 MW Load      2 MW DG**

**Benefit 1 MW**

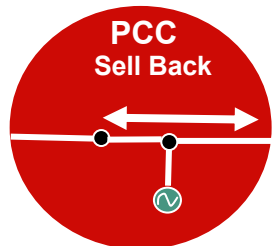

## **Distributed Generation in sellback mode**

**1 MW Load      2 MW DG**

**Benefit 2 MW**



# Circuit Example Calculation

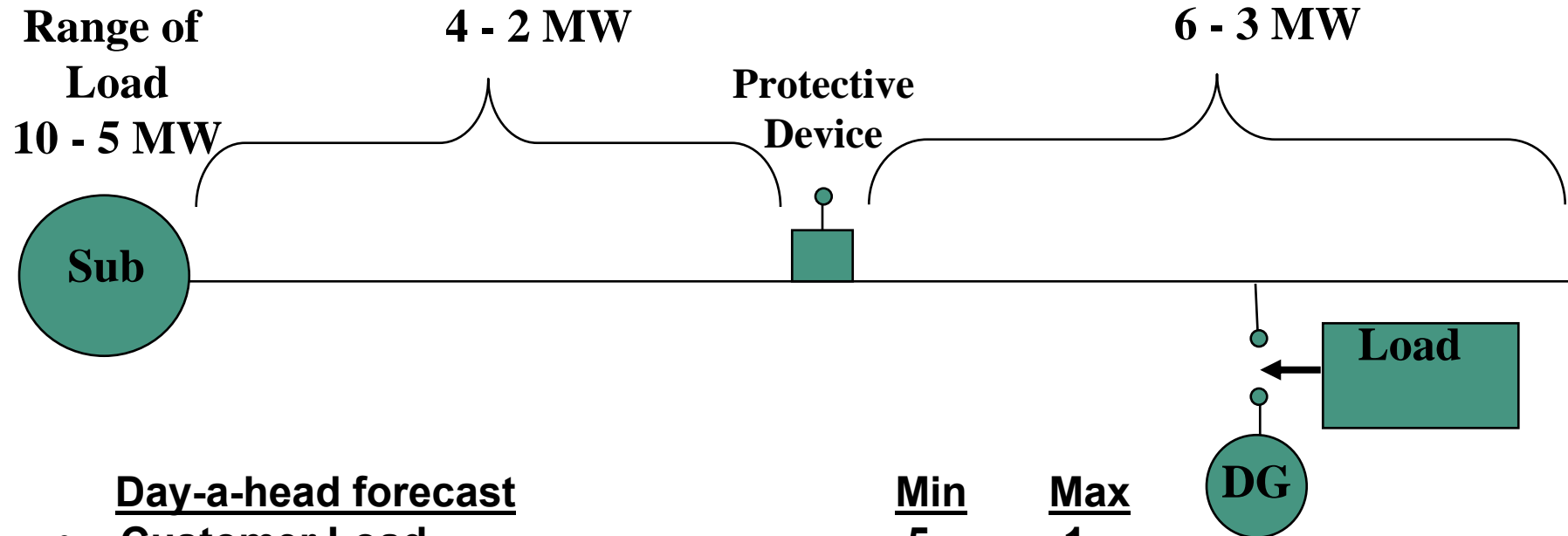

Day-a-head forecast

|                                       | <u>Min</u> | <u>Max</u> |
|---------------------------------------|------------|------------|
| • Customer Load                       | .5         | 1          |
| • Customer DG                         | 2          | 2          |
| • Standby sale                        | .5         | 1          |
| • Sellback sale with Transfer Trip    | 2          | 2          |
| • Sellback sale without Transfer Trip | 1 (3/3)    | 2 (6/3)    |

DG – Protective Zone restriction IEEE 1547 (Load to DG = 3 to 1)



## Project Timeline & Budget

- **Phase I**
  - **Completed February 2004**
  - **Project Budget \$255,197**
- **Phase II**
  - **October 2004 to July 2006**
  - **Project budget**
    - **FY 2005 \$300,000**
    - **FY 2006 \$231,387**
  - **DOE Share \$531,387**
  - **Recipient \$531,387**



## Impact and Benefits

- **This project establishes the process that will allow customer DERs to participate in the energy market and electric utilities to use DERs to manage their electric system**
- **Customer Benefits**
  - **Asset utilization**
  - **i.e. Oakland Water Board generator lease**
- **Utility benefits – Wires Company**
  - **Manage circuit loading**
    - **On peak**
    - **Shutdowns**
    - **Emergency**
- **Utility Benefits – Generation Company**
  - **Energy**
  - **Capacity**

# Contact Information

**Principal Investigator and Presenters**  
**Hawk Asgeirsson, Supervising Engineer**  
**Richard Seguin, Principal Engineer**  
**Distributed Resources Planning**  
**DTE Energy – Detroit Edison**  
**2000 2nd Avenue**  
**Detroit MI 48226**  
**[asgeirssonh@DTEenergy.com](mailto:asgeirssonh@DTEenergy.com)**  
**313-235-9371**  
**DE-FC02-04CH11234**

**DTE Energy®**





# Union Lake Example

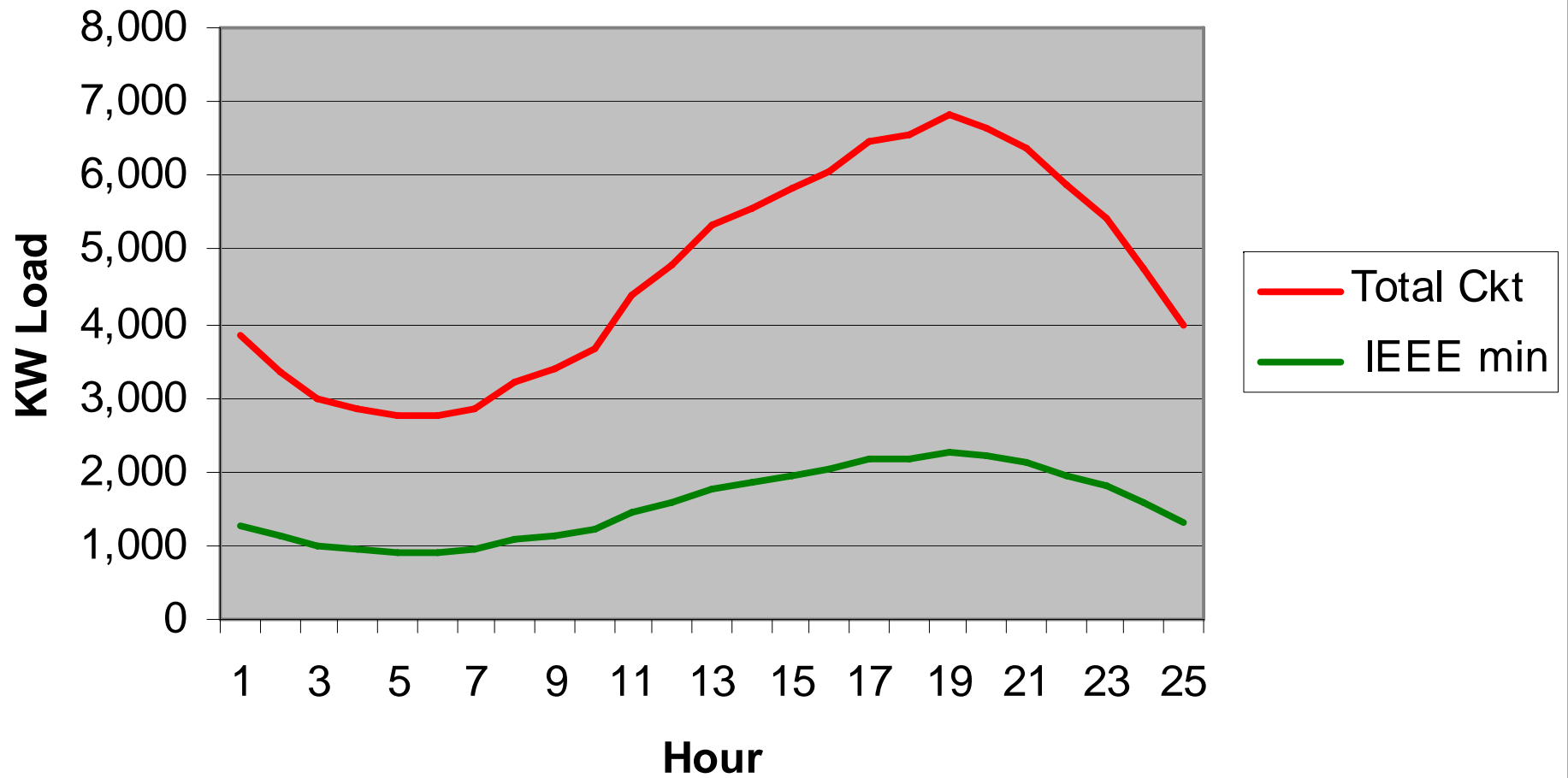



# Union Lake Example

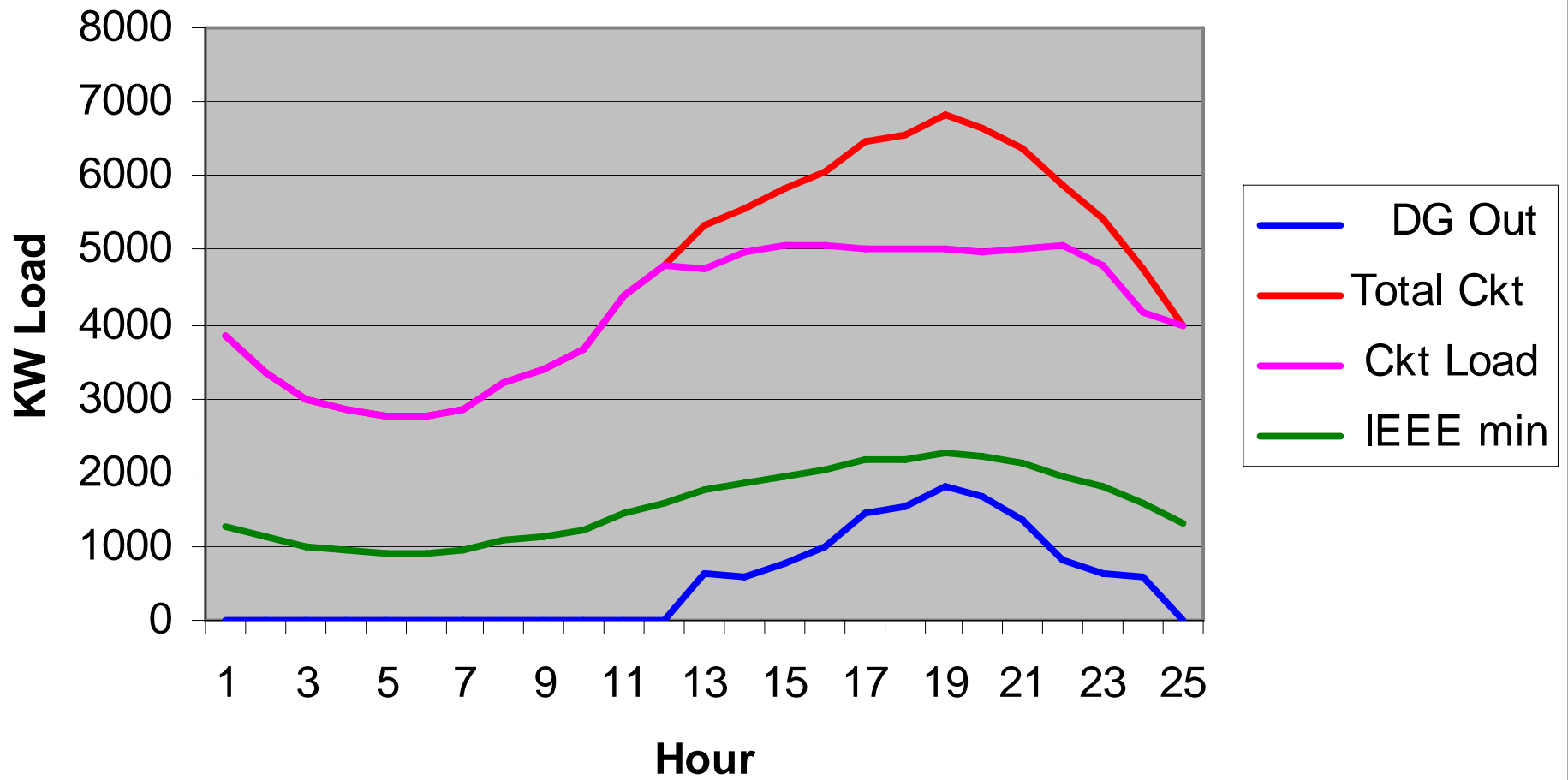



# Union Lake Example

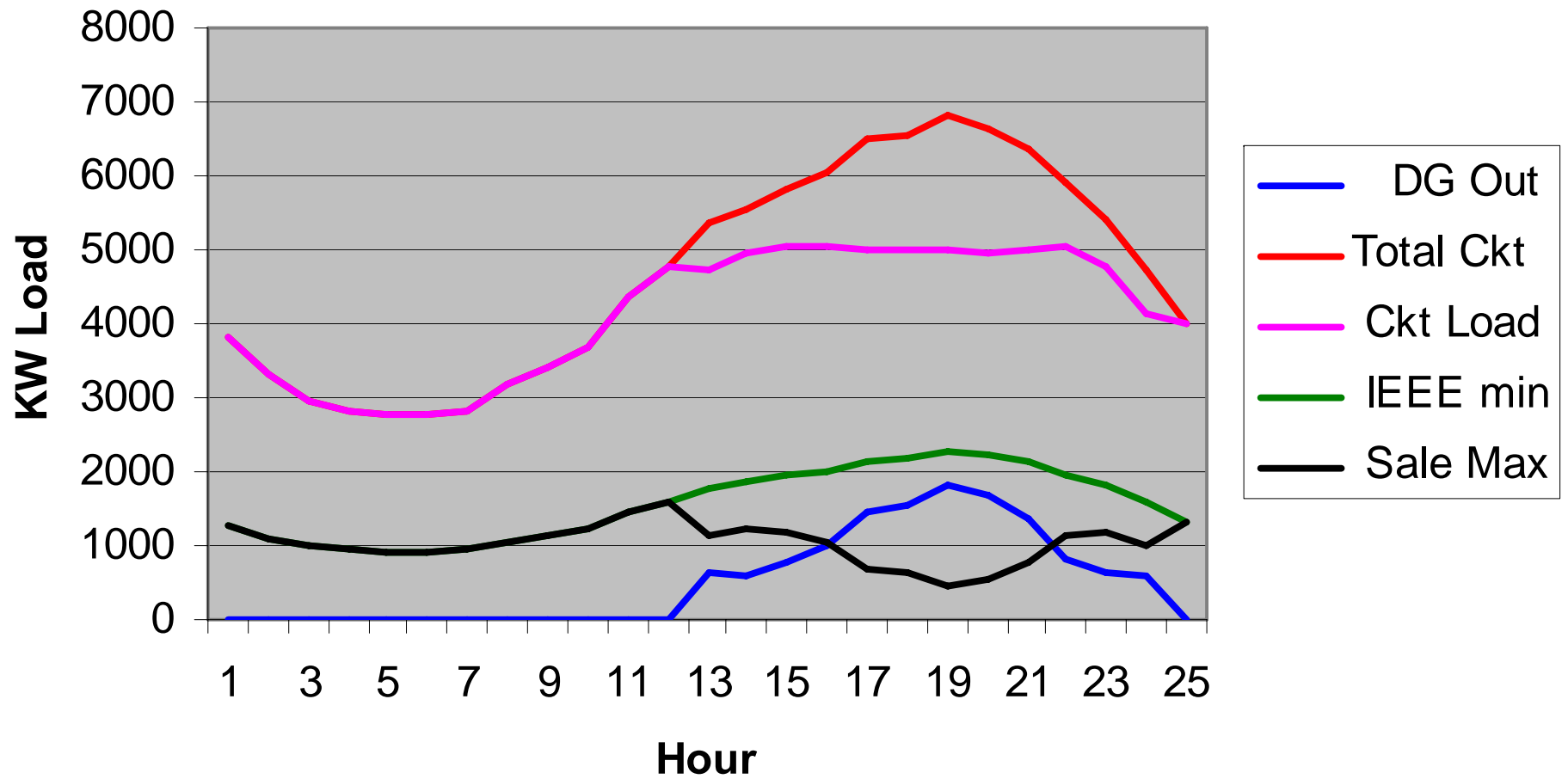



# Union Lake Example

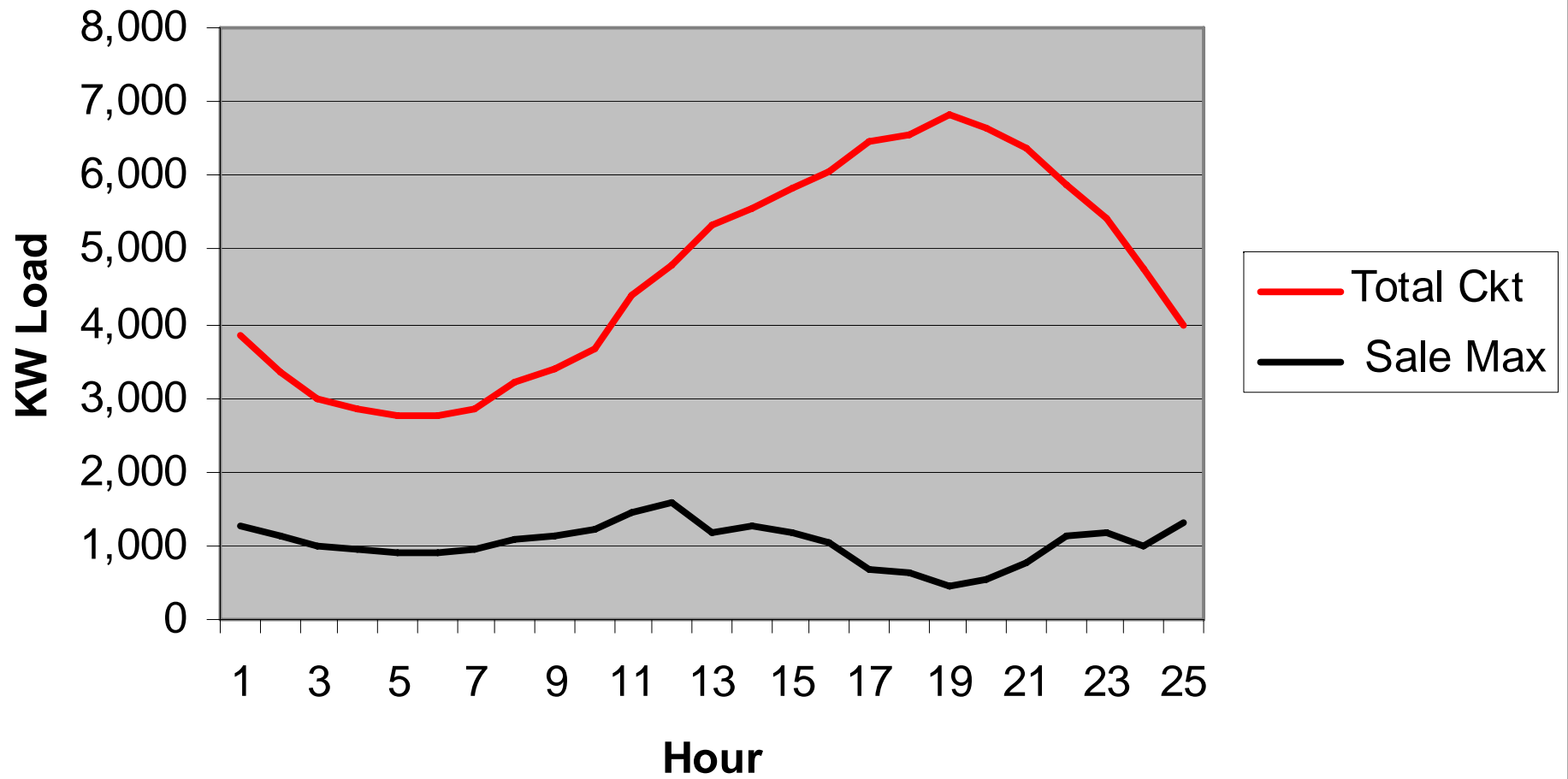



# Standby - Load Example

## Standby non-sellback

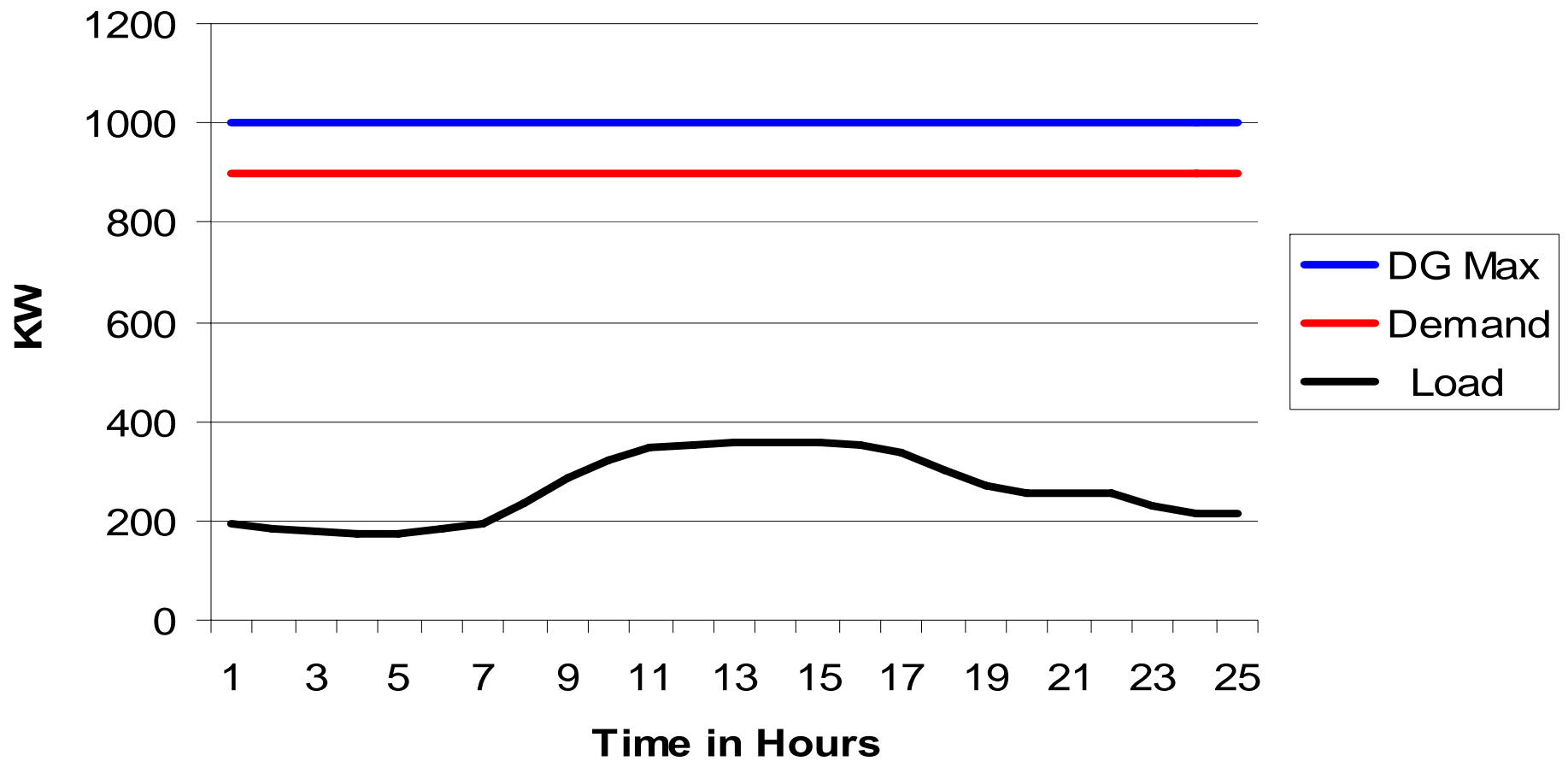



# Automatic Load Following

# Remote communication used for Load following (Radio works 95% of time with 65' antenna)



## Install Portable ACM at the Substation on Circuit

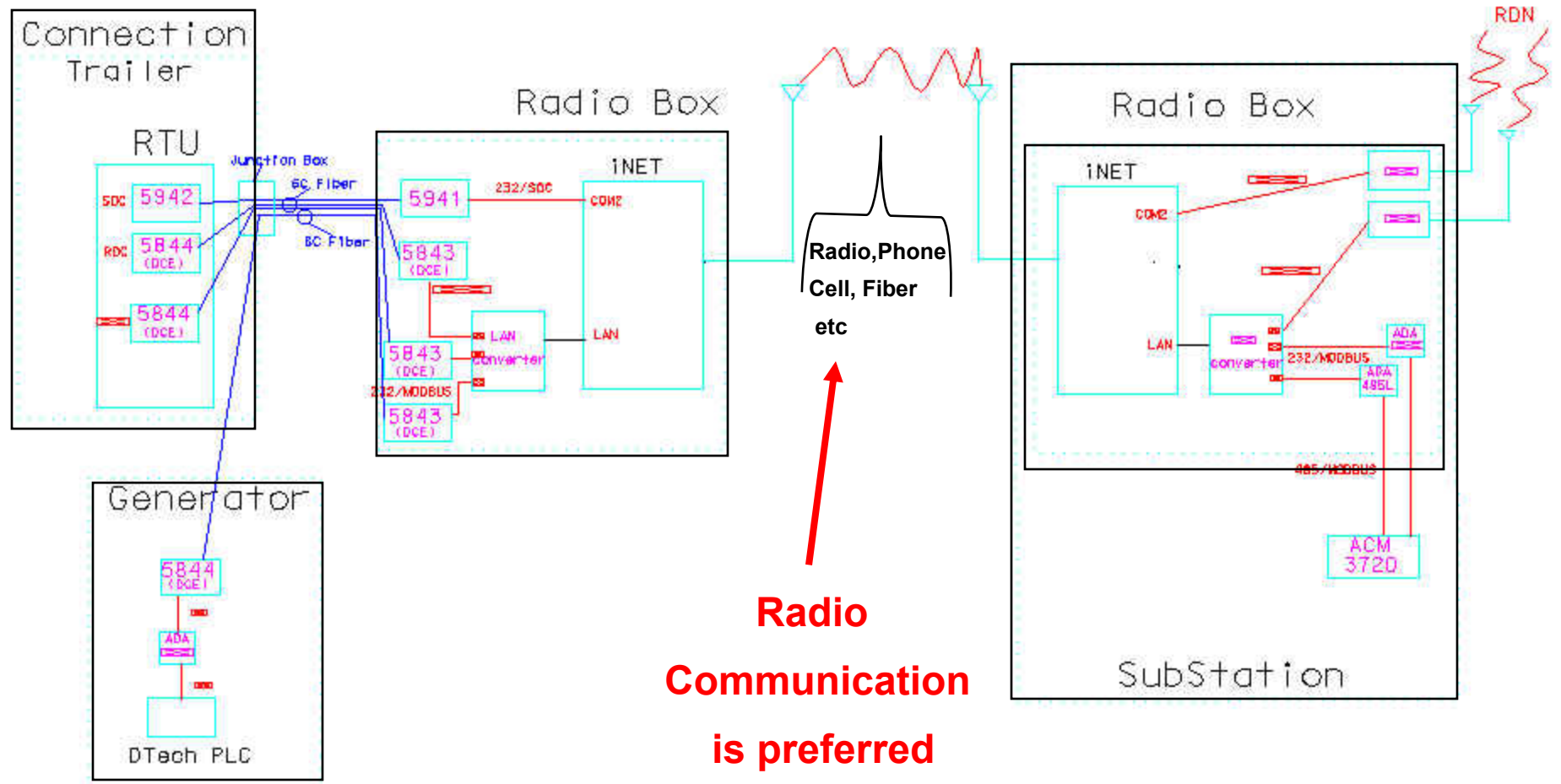

# Automatic Load Following

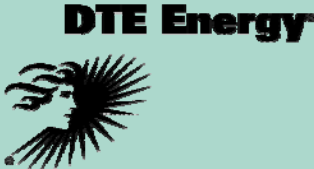

Adair Load Data

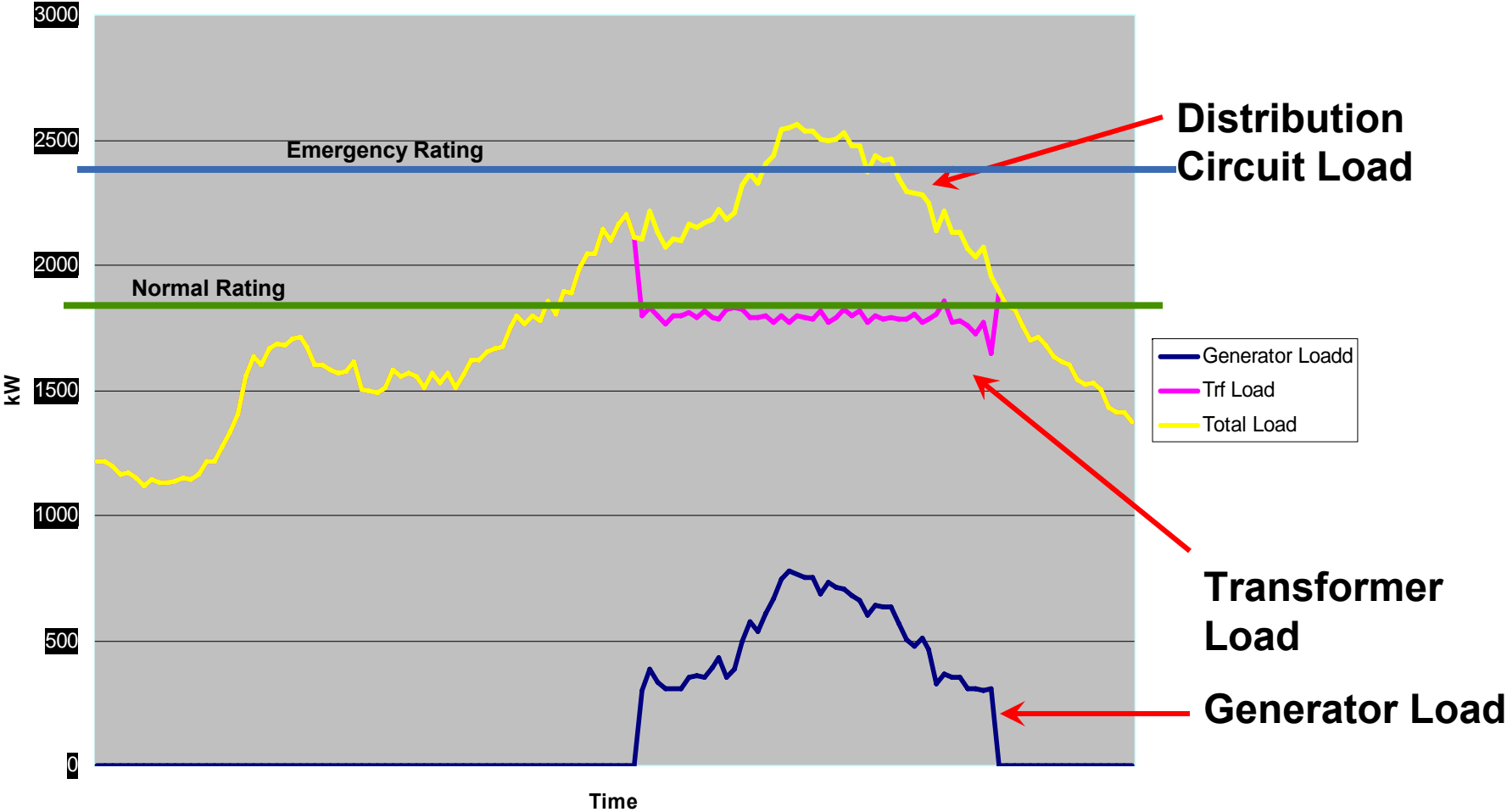

# Contingency Analysis and Reconfiguration with Shores DG



**Shores**



**Lakeside**



Day of the Peak  
Percentage Load Pickup  
0% without DG  
Up to 30% with DG

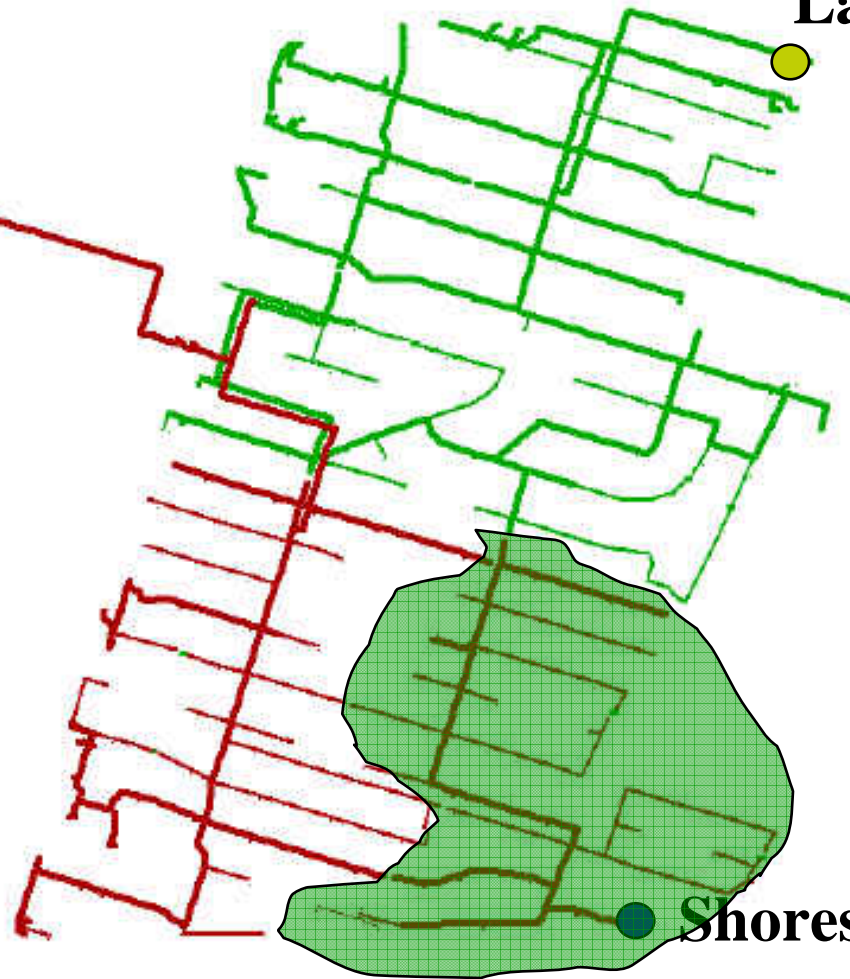

**Shores DG**

**DTE Energy**



# DOE Phase 3



# DG can provide peaking capacity

## Customer Annual Load Duration Curve (1)

Percent of Peak Load

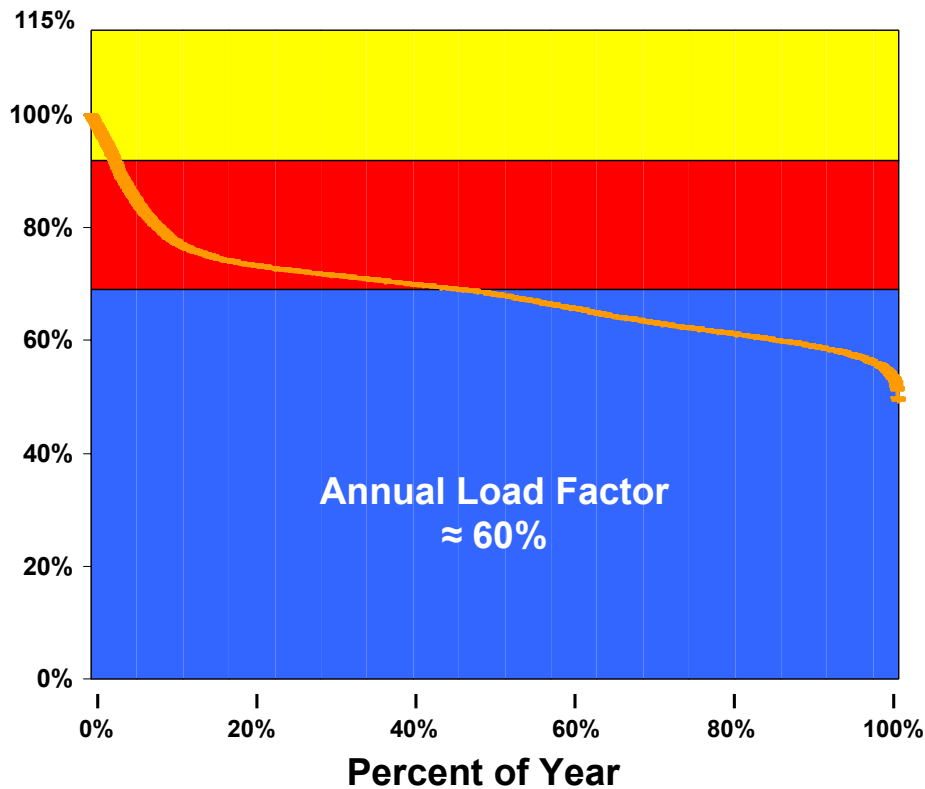

Plant Type



- Peak load plus required reserve margin establish amount of capacity
- Annual customer load factor and plant cost characteristics determine optimal least-cost generation mix
- DG can supply peaking capacity

Typical Range

|           |          |
|-----------|----------|
| Base load | 60 - 70% |
| Cycling   | 15 - 20% |
| Peaking   | 15 - 20% |

# Detroit Edison Service Area

DTE Energy

DTE Energy



Service Area: 7,600 Sq. Miles

Customers: 2.1 million

System Peak Load: 12,132 MW

Annual Sales: 56,000 GWH

37% Commercial

29% Residential

29% Industrial

5% Wholesale & Interconnection

Distributed Generation: 1,427 MW

or 12 % of Peak Load

(Does not include < 100kW units)

Distribution Substations 662

Distribution Circuits 2,808

1,876 @ 4.8kV

932 @ 13.2kV

Distribution Circuit Miles 38,939

20,184 @ 4.8kV

18,755 @ 13.2kV

Subtransmission 2,664 @ 24 kV

797 @ 41.6kV

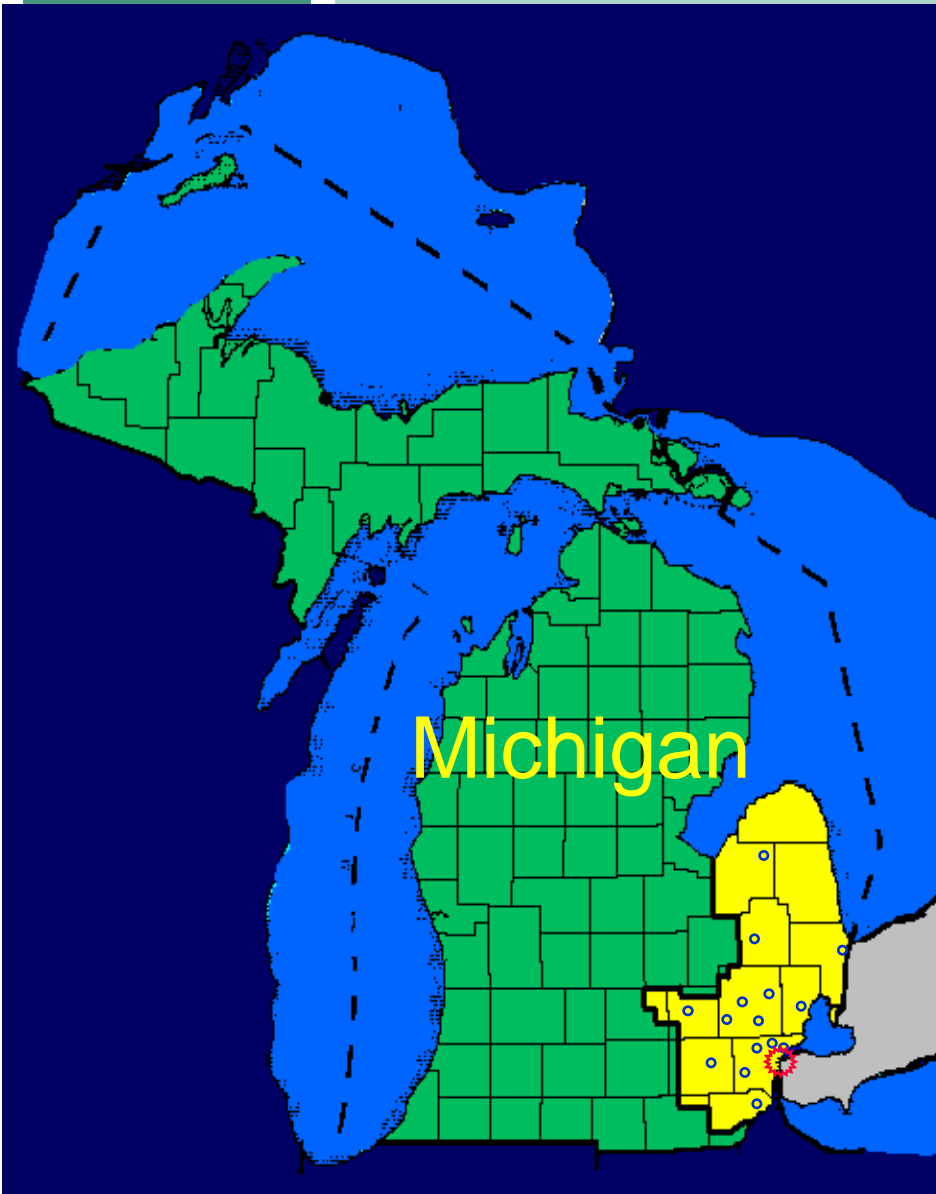

# Communication Architecture Real Time Model

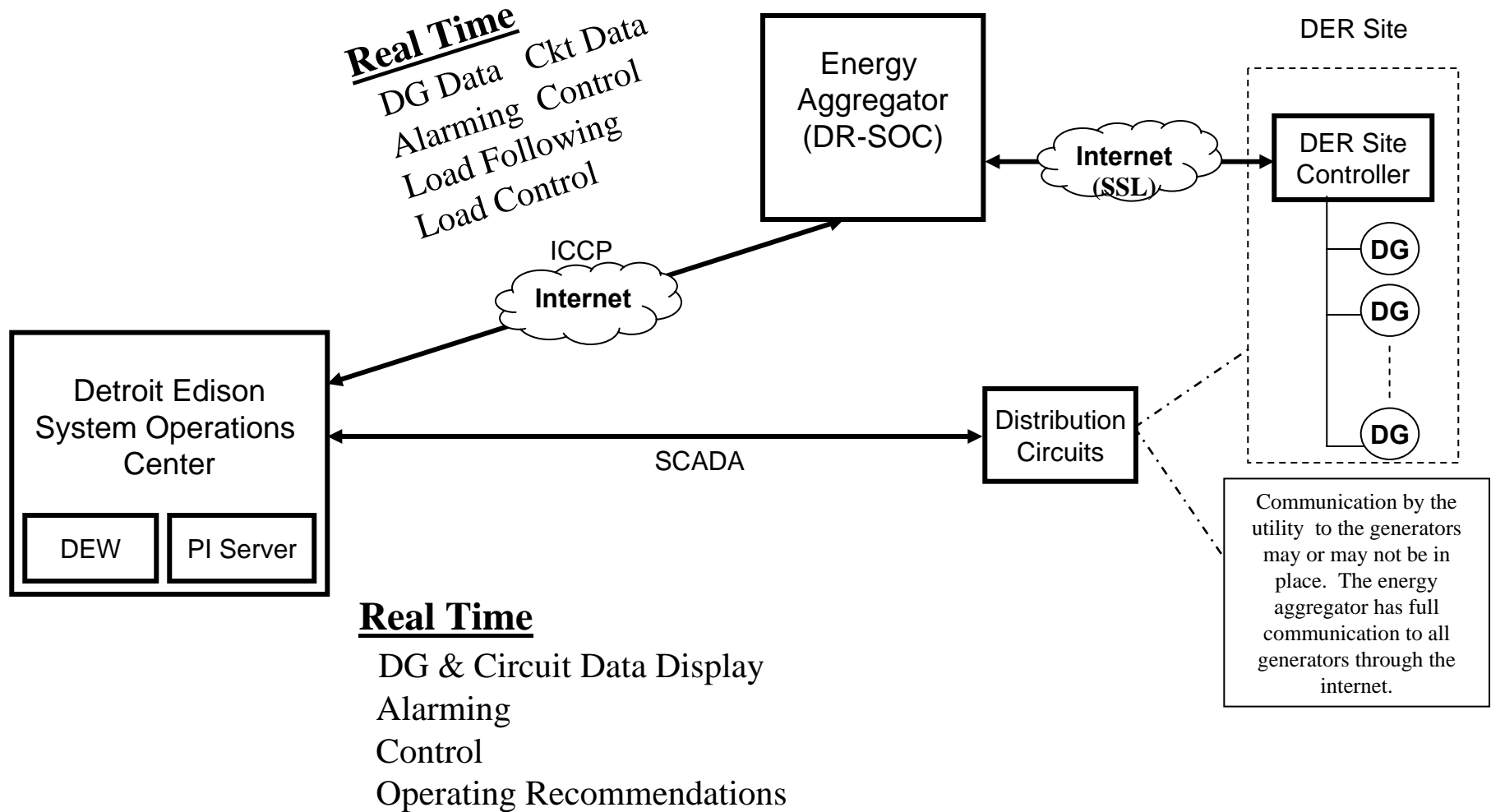



# Communication Architecture Day Ahead Business Model

